

BM2 Block Stopping Module

Feb 2006

Digital

plus
by Lenz[®]

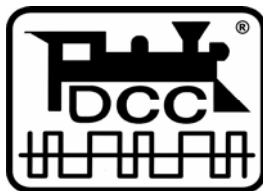

The ABC modules BM1, BM2 and BM3 may only be used with *Digital plus by Lenz*® or other standard digital control systems with a NMRA-conformance seal. If in doubt, ask the system supplier.

The current-carrying capacities stated below may not be exceeded as this could damage the block section module.

Technical Data:

| | |
|--|----------------------------------|
| Maximum continuous current-carrying capacity | 3.0 A |
| Voltage at signal input (AC or DC) | DC: 11...24 V AC: 8...24 V |
| Dimensions | 70 x 60 x 20 mm |

Requirements for using the ABC technology

To use the ABC technology with BM1, BM2 and BM3 block section modules, you will need locomotive decoders of the GOLD series or other decoders that support the ABC technology.

How does the ABC technology work?

With little effort, ABC manages to accomplish just what model railway enthusiasts crave: precise on-the-spot stopping in front of signals, slow approach and passage in the opposite direction.

By means of simple modules, which supply the braking section in front of a signal, an asymmetry is created in the otherwise symmetrical digital track voltage. Naturally, this

occurs only if the signal is at "Stop" or "Slow approach". This asymmetry informs the locomotive decoder about the signal status:

- A "Stop" or "Slow approach" signal indicates an asymmetry - the train will stop or slow down.
- A "Clear" signal indicates normal digital voltage - the train will continue.

Additional advantages of the ABC technology:

- All locomotive functions (e.g. front lighting) can still be switched while the locomotive stops in front of the signal.
- Programming in operational mode (POM) possible.
- The locomotive can reverse away again from the signal!
- A locomotive can pass in the opposite direction, even if the signal is at "Stop".
- Shunting is possible, even if the signal is at "Stop". Simply activate the shunting mode!
- No short-circuits when crossing section points between the driving and stopping sections.

Compared to the simple BM1, the BM2 module has the following advantages:

- In addition to signal stopping, "Slow approach" (HP2) is also possible.
- Easy control of the module using light signals and semaphore signals fitted with switches.
- Even rear-powered (pushed) trains (push-pull trains, commuter trains, motor coaches) stop at the right spot.

Depending on the signal setting, you can use the BM2 module to direct locomotives fitted with a GOLD decoder to stop (for HP0), to pass (for HP1) or to slowly approach (for HP2). Of course, you can set the speed for the slow approach in the locomotive decoder.

The BM2 has two control inputs. Depending on which one is active, the BM2 sends the information "STOP" or "SLOW"

APPROACH" to the locomotive equipped with the GOLD decoder.

Rear-powered trains (pushed) and push-pull (commuter) trains? – no problem!

Would you also like to use the "Signal stop" and "Slow approach" functions for rear-powered (pushed) trains and push-pull (commuter) trains?

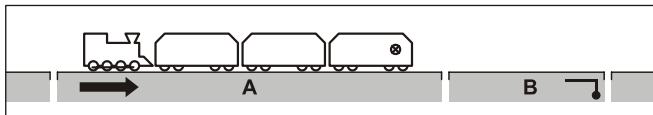

Divide the section in front of the signal into a driving (A) and a braking section (B).

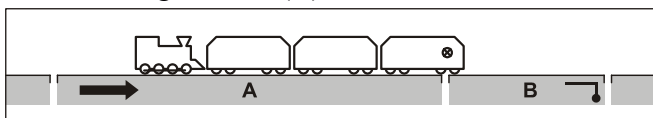

When the rear-powered (pushed) train in the driving section reaches the braking section, the BM2 switches the driving and braking sections to asymmetrical digital voltage. As the pushing locomotive is already located in the driving section at that time, the GOLD decoder recognises this asymmetry and switches to "Stop" or "Slow approach", depending on the signal setting.

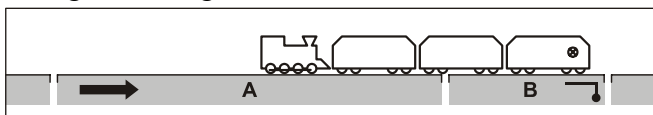

The length of the driving section must be calculated so as to fully accommodate the longest trains passing this section. The length of the braking section depends on the braking delay and/or distance set in the locomotive decoder. Trains passing in the opposite direction do not initiate a braking procedure.

The above procedure requires that the leading coach of the rear-powered (pushed) train is fitted with a power consumer, e.g. interior lighting.

Installing and connecting the BM2 module

The BM2 connections

A brief overview of the BM2 connections:

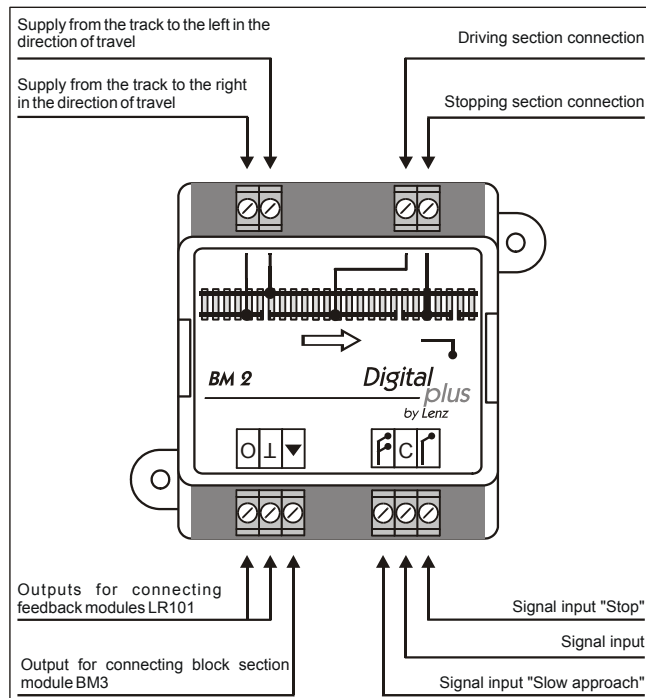

Figure 1

Installing the BM2

Length of driving and braking sections

First, define the length of the driving section (**A**). Keep in mind that the longest train on your layout must fit in this section!

Then, define the length of the braking section (**B**) in front of the signal. Keep in mind that the fastest train on your layout must be able to come to a standstill within this section. Use the feature "constant braking distance" of the GOLD decoder - this will ensure that all trains will come to a complete standstill within the braking section you have defined.

"On the right means on the right..."

... was a slogan on an Autobahn sign at the end of the 1980s. It was meant to remind drivers to change back to the right lane after overtaking a lorry.

The same is true when using the BM2 module: "on the right means on the right". It is always *the right rail in the direction of travel where a rail-break is made* when a driving or braking section is defined.

Make breaks in the right rail at the beginning and at the end of the braking section. Alternatively, you can use an insulating track connector if there is a track joint at the point in question.

Connecting the driving and braking sections

Connect terminal (1) to the right rail before the braking section.

Connect terminal (2) to the left continuous rail.

Connect the right isolated rail of the driving section to terminal (3) of the BM2.

Connect the right isolated rail of the braking section to terminal (4) of the BM2.

Connecting the signal inputs

For the BM2 to learn the signal status, the BM2 signal inputs will have to be wired correctly.

The signal inputs are voltage-controlled. If no voltage is applied to the signal input "Stop", the train will stop before the signal. If voltage is applied to this input, the train can pass, continue after a stop or slowly approach.

If voltage is applied to the signal input "Slow approach", the train will slowly pass.

The "Clear" input has priority over the "Slow approach" input. Therefore, if no voltage is applied to the "Clear" input, the train will be stopped in any event, even if voltage is applied to the "Slow approach" input.

You can use a control voltage between 8(AC)/11(DC) and 24(AC/DC).

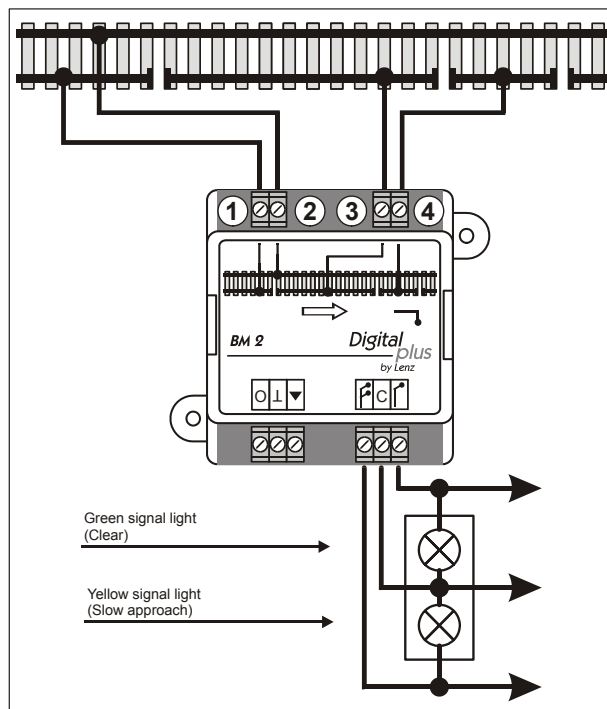

Figure 2

Using light signals

Simply connect the BM2 signal inputs to the bulbs of the light signal. When the light signal is set, the BM2 will know how to react.

Connect the signal input "Clear" to the *green* bulb of your light signal. This way, the signal input is self-securing: A train can only pass if voltage is applied. This means that if the power supply of the signal fails, the train will be stopped. If you also want to use the signal input "Slow approach", simply connect the respective terminal to the *yellow* bulb of the light signal. Note: If voltage is applied to this input, the BM2 will ensure that the passing train is slowed down to slow approach.

The "Clear" input has priority over the "Slow approach" input. Therefore, if no voltage is applied to the "Clear" input, the train will be stopped in any event, even if voltage is applied to the "Slow approach" input.

The table below shows the various possibilities:

| Train behavior | Light signal | Voltage at "Clear" input | Voltage at "Slow approach" input |
|----------------|----------------|--------------------------|----------------------------------|
| Stop | red | no | no |
| Clear | green | yes | no |
| Slow approach | green / yellow | yes | yes |

Using form signals

Form signals are usually equipped with switches that can be used to switch off the track voltage of a track section in front of a signal indicating "Stop". These switches can also be used to indicate the signal status to the BM2.

The figure below shows the connection of the form signal switches:

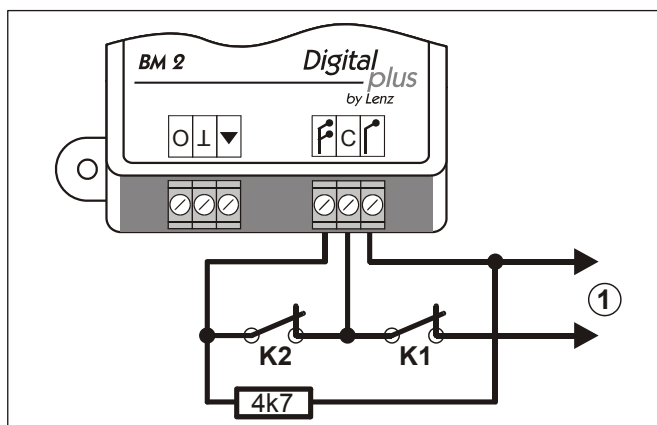

Figure 3

The signal inputs are voltage-controlled which means that you will need an additional AC/DC power source between 8(AC)/11(DC) and 24(AC/DC) V. This voltage must be fed into location (1).

The following applies to the K1 and K2 switches:

| Train behaviour | Form signal shows | K1 switch | K2 switch |
|-----------------|-------------------|-----------|-----------|
| Stop | | | |
| Clear | | | |
| Slow approach | | | |

Since the "K2" switch (Slow approach) is always designed to be open when the signal is at "Slow approach", a resistor (4k7, 1/4W), shown in Figure 3, must be installed. The resistor is enclosed with the BM2.

Testing the installation

To test the installation, you need a locomotive equipped with a decoder that supports the ABC technology, for example a GOLD decoder.

Leave the BM2 signal inputs unwired for the first test. As soon as it enters the braking section, the train should stop with the set braking delay or braking distance. If you use a rear-powered (pushed) train for this test, its leading coach must be fitted with a power consumer.

If the train does not stop, the set braking distance is probably too long or the braking section too short.

If the train stops abruptly immediately after entering the driving section, the connection between the BM2 and the track sections is probably faulty.

If the first test was successful, you can finish wiring the signal inputs and check whether the train passes a signal indicating "Clear", and slows down to the speed set in the decoder if a signal indicates "Slow approach".

Tips for use

Extended slow approach section

Do you want your train to stop in front of a signal indicating "Stop", while continuing slowly after a signal indicating "Slow approach"?

No problem: Simply extend the braking section beyond the signal's location, for example, beyond the points after the signal.

Set the constant braking distance in the decoder so that the locomotive stops in front of a signal indicating "Stop". If the signal indicates "Slow approach", the locomotive will continue slowly until the end of the braking section and, only then, accelerate to its original speed.

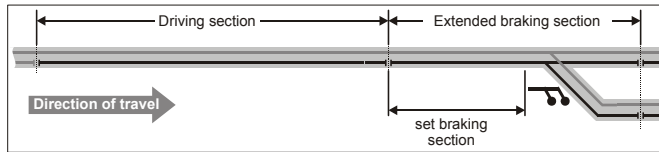

Push-pull operation

You can also use the BM2 for push-pull operation. Preferably, the BM2 module will be used where the rear-powered (pushed) train is to stop. In this case, a BM1 module suffices at the opposite stopping point.

Using the BM2 at the end of a block section

You can use the BM2 module to complete a block section of BM3 modules. In a typical case, the entry signal to a station would be at the end of a block section. By setting the entry signal, you, as the conductor, determine whether an arriving train may or may not enter the station.

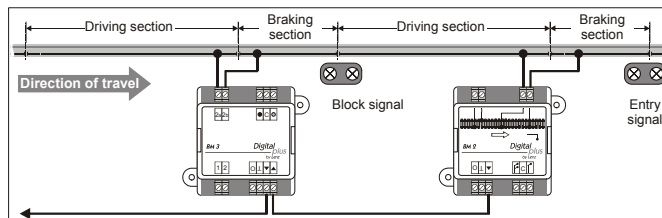

The BM2 has a control output designed for this purpose. Connect this output to the BM3 control input that controls the previous block.

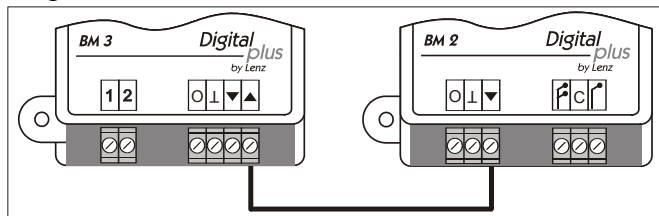

Connecting the BM2 to a feedback module LR101

If you want to verify the occupancy status of braking and driving sections by means of the feedback function of the Digital plus system, simply connect the BM2 to a LR101 feedback module:

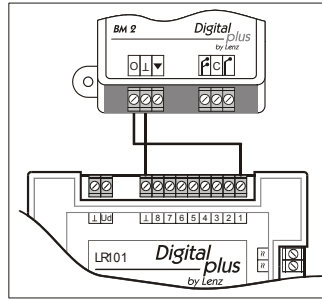

- Connect output (O) to one of the eight inputs of the LR101,
- and output (⊥) to the terminal (⊥) of the LR101.

As soon as a power consumer enters the driving or braking sections, the occupancy status will be transmitted to the command station via the R-S bus.

North American Warranty

Lenz GmbH does everything it can do to ensure that its products are free from defects and will operate for the life of your model railroad equipment. From time to time even the best engineered products fail either due to a faulty part or from accidental mistakes in installation. To protect your investment in Digital plus products, Lenz GmbH offers a very aggressive 10 year Limited Warranty.

This warranty is not valid if the user has altered, intentionally misused the Digital Plus product, or removed the product's protection, for example the heat shrink from decoders and other devices. In this case a service charge will be applied for all repairs or replacements. Should the user desire to alter a Digital Plus Product, they should contact Lenz GmbH for prior authorization.

Year One: A full repair or replacement will be provided to the original purchaser for any item that has failed due to manufacturer defects or failures caused by accidental user installation problems. Should the item no longer be produced and the item is not repairable, a similar item will be substituted at the manufacturer's discretion. The user must pay for shipping to an authorized Lenz GmbH warranty center.

Year 2 and 3: A full replacement for any item will be provided that has failed due to manufacturer defects. If the failure was caused by accidental user installation or use, a minimal service charge may be imposed. Should the item no longer be produced and the item is not repairable, a similar item will be substituted at the manufacturer's discretion. The user must pay shipping to and from the authorized Lenz GmbH warranty center during this portion of the warranty period.

Year 4-10: A minimal service charge will be placed on each item that has failed due to manufacturer defects and/or accidental user installation problems. Should the item no longer be produced and the item is not repairable, a similar item will be substituted at the manufacturer's discretion. The user must pay shipping to and from the authorized Lenz GmbH warranty center during this portion of the warranty period.

Please contact your dealer or authorized Lenz GmbH warranty center for specific instructions and current service charges prior to returning any equipment for repair.

Hüttenbergstraße 29
35398 Gießen, Germany
Hotline: 06403 900 133
Fax: 06403 900155
info@digital-plus.de

Lenz
ELEKTRONIK GMBH
<http://www.lenz.com>

Lenz Agency of North America
PO Box 143
Chelmsford, MA 01824
ph: 978 250 1494
fax: 978 455 LENZ
support@lenz.com

This equipment complies with Part 15 of FCC Rules. Operation is subject to the following two conditions: (1) this device may not cause harmful interference, and (2) this device must accept any interference received, including interference that may cause undesired operation.

Ⓒ Please save this manual for future reference!

© 2002 Lenz GmbH, All Rights Reserved