

The DIGITAL plus GOLD locomotive decoder is suitable for all DC locomotives with continuous current draw of 1.0 Amp. or less. The characteristics of the decoder are:

- * Super smooth and silent high frequency back-emf motor control.
- * Supports the industry proposed enhancements to the NMRA DCC Bidirectional data communication RPs
- * USP with optional power module for operation on dirty track
- * Asymmetric DCC support including directional stopping
- * Adjustable precision stopping control
- * Low speed gear for switching operations
- * Selectable for operation with 14/27, or 28/128 speed steps.
- * Operation on conventional DC layouts is possible or can be disabled.
- * Motor output = 1A continuous, 1.8A max, > 5 A stall.
- * Motor and function outputs protected
- * Four function outputs rated at 200mA each with advanced function mapping
- * Directional or independent lighting with dimming and special effects.
- * Support for Advanced Consist Control and Extended Addressing
- * Support for programming on the mainline (operations mode programming)
- * Support for all form of programming as described in NMRA RP-9.2.3
- * Supports service mode decoder lock
- * Size: L 0.91" x W 0.66"x H 0.2" L 23.0 mm x W 16.5 mm x H 6.5 mm

Gold-JST Silent-Back EMF DCC Decoder

Art. No. 10432/10433
June 2006

Digital

plus
by Lenz®

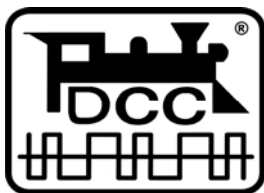

GOLD Decoder feature set

The following contains a short introduction of the features of the GOLD decoder as well as information on how to use them.

For more detailed information please refer to the "GOLD decoder" information which can be downloaded from the Lenz Elektronik GmbH website: www.lenz.com.

Capacity and protection equipment

The motor output has a current-carrying capacity of up to 1A without any concern for cooling! The short-term maximum current-carrying capacity is 1.8A. The decoder is protected against overloading, short circuits and overheating. In case of a fault, a bit is set in CV30 which will state the type of fault which has occurred. This bit can be cleared via setting this CV to 0. Because of this protection the Gold decoder can work with motors that have very high stall currents.

Maximum continuous current-carrying capacity of total decoder	1.0 Amps
Motor output - Continuous / maximum power / Stall	1.0 Amps / 1.8 Amps / NA
Function output A, B, C and D	200 mA each
Total current-carrying capacity of function outputs	500 mA

High Frequency Back EMF Motor control

Gold decoders have a very smooth and quiet high-frequency motor control (23kHz). If necessary, the performance of the decoder can be optimized to one of 6 specific motor types in the locomotive using CV50. These motor types include parameter sets which have been specially adapted to the respective models. In addition, it is possible to perform additional fine-tuning via CV113 or CV114 when selecting motor types 4 or 5. If desired you can switch off both the high-frequency drive as well as the control system itself. You can still use CV9 to adjust the repetition rate.

The minimum (CV2), maximum (CV5) and mid (CV6) speeds can be set; the decoder automatically adapts these desired speed parameters dynamically to ensure a steady, smooth curve. It is also possible to program a user defined unique speed curve.

The decoder also has what we refer to as a EMF switch which makes it possible to further adjust the decoder to different motor types. Depending on the motor type used, it is possible that a digitally controlled locomotive cannot reach an adequate maximum speed compared to a locomotive in conventional operation. If this is the case, activate your EMF switch by setting Bit 6 in CV 50. The locomotive will then reach a higher maximum speed while the minimum speed is also slightly increased.

Special Features

Function for disabling of acceleration and deceleration delay

Use function F4 (function assignment can be altered in CV59) to disable the acceleration and braking delay as well as the constant braking distance during operation. The delays are disabled as long as the function is active.

Switching speed function

The switching speed halves the speed table. This facilitates particularly sensitive control during the switching process. Use function 3 (function setting, can be altered in CV58) to enable and disable the switching speed. If the shunting speed is enabled, the constant braking distance is disabled. The switching speed is enabled as long as the function is active

Constant braking distance

During the transition from an active speed step to speed step 0 (e.g. moving the speed control knob to the left limit-stop), the locomotive/train will travel a settable, pre-defined braking distance. This braking distance does not depend on the speed of the locomotive/train.

Enable the constant braking distance function (this requires setting Bit 0(1) in CV51. If this bit is not set, the decoder will use the normal speed-dependent braking delay).

The braking distance is defined by the value set in CV52. Since the motors and gear ratios of locomotives vary, the braking distance differs from locomotive to locomotive even if the same value is set in CV52.

Use a short test section to measure how long your locomotive's braking distance will be with a given value set in CV52. Start with the default value (100) in CV52.

Accelerate your locomotive until it has reached average speed.

At a chosen point in time, set the speed to 0. This requires moving the speed control to the stop position, if you are using the LH100, keep pressing the < key until the speed is set to 0 or until the locomotive address is displayed (if using the LH100, do not press key <⊞>! This result in a locomotive-specific emergency stop and the delays in the locomotive decoder will not be enabled!).

Measure the covered braking distance.

Increase or decrease the value in CV52, e.g. in steps of 10, and carry out another measurement. You will thus create a table which will indicate the braking distances in relation to the values set in CV52.

Important advice: The constant braking distance is only effective if the speed is changed to 0. If the speed is decreased from e.g. 28 to 10, the speed-dependent delay from CV4 becomes effective.

The constant braking distance is disabled while the switching speed function is switched on (default setting F3), or if the function to disable acceleration/deceleration is activated (default setting F4). Either of these two features can also be used if you wish to interrupt a constant braking process prematurely.

The constant braking distance does not function in analogue DC mode.

Mapping function outputs

Using function mapping (CVs 33-46) you can define which functions of the digital system are used to control the A, B, C and D function outputs. The outputs A, B and C can be allocated to function F0 (direction-dependent) or functions F1 to F8 as desired. Output D can be allocated to function F0 (direction-dependent) or functions F1 to F12 as desired.

Lighting effect at function outputs

Special lighting effects can be assigned to each of the function outputs. The lighting effects for the function outputs A and B are set in CV60 and for the function outputs C and D in CV62. If you wish to switch the effects with a function of the digital system, you can make the allocations to functions F1 to F8 in CV61 (for function outputs A and B) and CV64 (for function outputs C and D). The effects available are shown in the CV table defined later in this manual.

Asymmetric DCC = Automatic Braking Control simple signal stop and slow approach

You can carry out a particularly simple stop at a signal using the ABC braking module. Depending on the signal position, this module creates an asymmetric track voltage in the braking section in front of the signal. The decoder reacts to this. Combined with the constant braking distance, precise on-the-spot stopping in front of red signals is not a problem. Of course, passage in the opposite direction is also possible. The signal indication "slow approach/caution" can be set using CV53.

You can operate all functions during the signal stop or slow approach – you can even reverse away again from the red signal! These special ABC modules can be used to assemble a very simple block section.

Activate the ABC control by setting Bit 2 (1) in CV51.

Push-pull train control

A push-pull train control can be set if the ABC braking module is used. There are two different options: push-pull operation with and without intermediate stops. The latter also takes slow-approach sections into account.

The push-pull train control is activated in CV51, Bit 4 (3) and Bit 5 (4). The stopping time at the end of the track is set in CV54 (1 to 255 sec).

The S.U.S.I. interface

The purpose of the interface is to facilitate a particularly easy connection of sound and other function modules to locomotive decoders. The S.U.S.I. module receives information about the speed, the status of the functions etc. via the interface and reacts accordingly, for example the sound of a bell is played or the locomotive sound changes. The quality of these sound effects depends solely on the S.U.S.I. module and not on the locomotive decoder!

Connecting a S.U.S.I. module

You may connect all sound and/or function modules to the S.U.S.I. interface which correspond to the interface's specification. 4 soldering surfaces are provided on the decoder for the connection of sound or function modules. The occupation of these soldering surfaces is selected in accordance with the specification of the S.U.S.I. interface. The cable colors stated correspond to the recommendations of this specification.

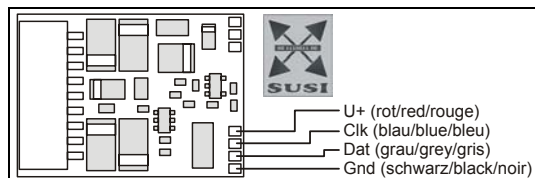

Setting (programming) the S.U.S.I. module

Like locomotive decoders, there are also various ways of setting the CVs in the S.U.S.I. modules. If you wish to change these CVs, proceed as if you wanted to change the CVs of the locomotive decoder. The S.U.S.I. module is programmed "through the decoder" as it were. When using Digital plus by Lenz® systems, you can change CVs 1 to 999 with PoM, while "Programming on the programming track" is currently used for CVs 1 to 256. CVs 897 to 1024 have been defined for the S.U.S.I. module. A special programming method has been built into this decoder so that these CVs can be reached. In this programming method, CV126 functions as a CV indicator and CV127 as a transport CV for the reading or setting the value.

USP - Uninterruptable Signal Processing

The intelligent USP circuit works in combination with the optional energy storage module to ensure that the locomotive can be fully controlled even over dirty track sections or dead frogs. The energy storage is not included with this decoder and is installed separately in the vehicle.

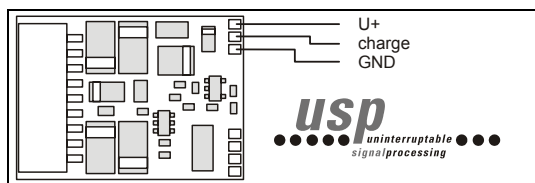

Soldering surfaces are provided on the decoder for the connection of the energy storage (e.g. Power 1). Solder the respective cable of your energy storage to the soldering surfaces. Make sure that you do not create short circuits to other surfaces or between connections.

RailCom = NMRA Bi-Directional DCC

The GOLD decoder is equipped with RailCom communications which allows the decoder to transmit its address, as well as other key data such as speed and CV contents. The information sent is received by a RailCom detector and then displayed. Which RailCom data is transmitted by the decoder is set in CV28. RailCom is enabled in CV29 bit 4.

Preparing to Install the GOLD decoder

A locomotive that runs well under DC will run exceptionally well under DCC. Replace worn out motor brushes and burned out light bulbs. Clean any dirt or oxidation from the wheels and pickups, and make sure that electrical contact is good. Now is also a good time to lubricate your locomotive.

Some advice on installing the decoder:

Although the GOLD decoder has many internal safeguards to prevent damage, you must not allow any metal part of the locomotive to touch the surface components of the decoder. This could cause a direct internal short circuit and the decoder will be destroyed. **The motor brushes MUST also be completely isolated from the rail pickup.** Achieving isolation may require some different approaches on different locomotives, perhaps unsoldering wires or placing a thin piece of insulating plastic between the motor and the locomotive frame. If you have a VOM, check for infinite resistance between the motor and all the wheels. Take special note that a short might occur when the loco body is reinstalled.

DO NOT WRAP decoder with electrical tape or shrink wrap!

Doing so will impede air circulation and degrade the performance of the decoder. Instead, put electrician tape over any part of the locomotive frame or body that might touch the decoder and use double sided foam mounting tape to mount the decoder. This will prevent short circuits without 'suffocating' the decoder.

The GOLD decoder can not be set up for simultaneous use for 2-rail pickup and overhead cantenary or trolley operation. If the locomotive is turned the wrong way, the decoder could get twice the track voltage, which would destroy it!

Wiring Options

There are two wiring options for installing the GOLD, depending on how the locomotive is constructed. The functions could be connected with their common to the decoders floating common (blue wire) as shown below or one rail can be used as a common. A mixture of both options is also possible.

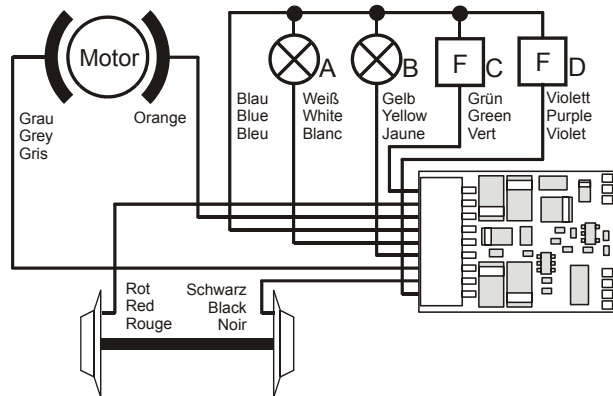

If the bulbs for the directional headlights are floating (isolated against wheel pick up and chassis) and connected according to above figure, they will shine brighter compared to using the rail as a common and the directional headlights will function while operating on conventional DC layouts.

Step by Step Installation

If the locomotive has a NMRA JST decoder plug simply remove the dummy plug from the locomotive's JST connector and plug the locomotive JST plug into the decoder.

If the locomotive has a NMRA 8 pin socket and the decoder has a 8 pin NMRA medium plug harness simply remove the dummy plug from the locomotive and plug in the decoder. The following instructions apply if you need to install the wired version.

Two wires connect the decoder to the motor. Make sure that the motor is electrically isolated from both track pickups:

- Orange wire to the motor terminal that was previously connected to the right rail (Pin #1).
- Gray wire to the motor terminal that was previously connected to the left rail (Pin #5).

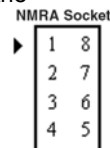

Two wires connect the decoder to the track electrical pickups:

- Red wire to right rail pickup (Pin #8).
- Black wire to the left rail pickup (Pin #4).

Five wires connect the headlights and functions to the decoder:

- White wire (Pin #6) to the forward headlight or the function controlled by Output A. If the bulb is isolated, connect the blue wire (Pin #7) to the other terminal.
- Yellow wire (Pin #2) to the rear headlight or the function controlled by Output B. If the bulb or function is isolated, then connect the blue wire (Pin #7) to the other terminal.
- Green wire (Pin #3) to function controlled by Output C. If the bulb is isolated, connect the blue wire (Pin #7) to the other terminal.

- Violet wire to function controlled by Output D. If the bulb is isolated, connect the blue wire (Pin #7) to the other terminal.

Place the locomotive (without its shell) on the programming track and read back the locomotive's address from the decoder. If the decoder is properly installed, you will be able to read back the factory pre-set address 03. Remove the locomotive from the track, and if necessary correct any wiring errors.

Configuring the Gold Decoder

The locomotive address, acceleration and deceleration delay, and all other features of the locomotive decoder can be changed as often as desired by reprogramming the decoder. The features are "stored" permanently in special locations even when the operational voltage is switched off. These locations are called "configuration variables" or simply "CV". The values are configured electronically, which means that it is not necessary to open the locomotive again after the decoder has been installed.

You can alter the content of CVs both through "Programming in operational mode (PoM)" (except for CV1, CV17 and CV18) or "Programming on the programming track".

For detailed instructions on how to program using the above-mentioned devices, please refer to the operating manuals which accompany those devices.

The decoder is programmed from the factory for operation with address 3 and 28 speed steps. The decoder can be used with these basic configurations immediately after purchase. All configurations can, of course, be changed.

Resetting the decoder

If you wish to reset all the decoder CVs to its factory setting, enter value 33 in CV8. The CVs of a connected S.U.S.I. module are not reset!

Please note: Some CVs (such as CV29) have specific meanings for each bit. The bit assignments in this table use a bit numbering scheme of 0-7 to correspond the NMRA convention for universal bit numbering. Many handhelds (such as the DIGITAL plus LH100 handheld) use a scheme of 1-8 to refer to the individual bits rather than 0-7. (Bit 0 in this table is displayed as a "1" on LH100 handheld, Bit 1 is identified as "2".) The bit numbers in () within these tables contain the LH100 bit numbers.

**Note: in the range field the numbers in the [] are decimal.

Table of supported CVs

CV	Meaning	Range	Factory setting
1	Basic locomotive address. This number is the short address used to control the locomotive. When writing this CV, CV19 (consist address) is automatically cleared and CV29 Bit 6 (use of extended address) is deleted is set to 0.	1-127	3
2	Minimum starting voltage	0-255	0
3	Starting delay	0-255	6
4	Braking delay	0-255	5
5	Maximum speed	0-255	255
6	Mid speed Vmid (a value of 60 will give a linear curve)	0-255	48
7	Version number	-	71
8	Manufacturer's ID	-	99
9	Back EMF Repetition Rate	0-63	15
17	Extended locomotive address, high-order byte	192-231	192
18	Extended locomotive address, low-order byte	0-255	100
19	Consist address	1-99	0
28	RailCom configuration		3 (dec)
	bit 0 (1) = 1 channel 1 used for address broadcast	0,1 [1]	1
	bit 1 (2) = 1 channel 2 used for data	0,1 [2]	1
	bit 2 (3) = 1 channel 1 used for command acknowledge	0,1 [4]	0
29	Decoder Configuration, Byte 1:		6 (dec)
	bit 0 Locomotive direction of travel:	0,1	0
	(1) 0 = locomotive's direction is normal	[1]	
	1 = locomotive's direction is reversed		
	bit 1 Headlight mode:	0,1	1
	(2) 0 = Operation with 14 or 27 speed step systems..	[2]	
	1 = Operation with 28, 55 or 128 speed steps.		
	Note: your system must be set to the same mode.		
	bit 2 Usage on conventional DC layouts:	0,1	1
	(3) 0 = locomotive operates in digital mode only	[4]	
	1 = locomotive can operate on either conventional DC and on DCC		
	bit 3 Enable RailCom	0,1	0
	(4) 0 = RailCom transmission disabled	[8]	
	1 = RailCom transmission enabled		
	bit 4 Speed Curve Selection:	0,1	0
	(5) 0 = factory pre-set speed curve is used	[16]	
	1 = user defined speed curve is used. Please enter the appropriate values into CV 67 to 94 before setting this bit.		
	bit 5 Extended Addressing	0-1	0
	(6) 0= Normal addressing	[32]	
	1= Four digit extended addressing		
	bit 6 bit 7 always 0	0	0

30	Fault indication					0 (dec)
	bit 0 (1) = 1	Light short-circuit		0,1 [1]		0
	bit 1 (2) = 1	Overheating		0,1 [2]		0
	bit 2 (3) = 1	Motor short-circuit		0,1 [4]		0
CV	Function mapping for function outputs:					Factory setting
33	In order to allocate a function of the digital system to a function output, look for the section where the row of the desired function meets the column of the desired function output. Enter the number found in the respective CV. For the purpose of clarification, factory settings are shown in bold print.					
46						
CV	Function output:	A	B	C	D	
33	F0 forward	8	16	32	64	8
34	F0 backward	8	16	32	64	16
35	Function 1	8	16	32	64	32
36	Function 2	8	16	32	64	64
37	Function 3	8	16	32	64	128 (*)
38	Function 4	1	2	4	8	32 (*)
39	Function 5	1	2	4	8	64 (*)
40	Function 6	1	2	4	8	128 (*)
41	Function 7	1	2	4	8	0
42	Function 8	1	2	4	8	0
43	Function 9	This range does not allow mapping of functions			1	0
44	Function 10				1	0
45	Function 11				1	0
46	Function 12				1	0
	(*)-These values are not significant for GOLD 10432 and 10433.					
50	Motor configuration					0 (dec)
	bits 0-3 (1-4)	Select motor type 0-5, enter as decimal number		0,1 [0-5]		0
	Bit 5 (6)	=0 Normal Back EMF control =1 Back EMF Control for high efficiency motors		0,1 [32]		0
	Bit 6 (7)	=0 Back EMF activated =1 Back EMF is turned off		0,1 [64]		0
	Bit 7 (8)	=0 High-frequency motor control (approx. 23 kHz) =1 Low-frequency motor control (approx. 19 Hz)		0,1 [128]		0
51	Braking configuration					0 (dec)
	bit 0 (1)	= 1 Constant braking distance activated		0,1 [1]		0
	bit 1 (2)	= 1 ABC activated		0,1 [2]		0
	bit 2 (3)	= 1 ABC direction-dependency deactivated		0,1 [4]		0
	bit 3 (4)	= 1 Activate push-pull operation without intermediate stop		0,1 [8]		0
	bit 4 (5)	= 1 Activate push-pull operation with intermediate stop		0,1 [16]		0
	bit 5 (6)	= 1 Stopping with DC independent of the polarity (only if Bit 3 is deleted in CV29).		0,1 [32]		0
	bits 6-7 (7-8)	Not used				0
52	Braking distance with activated constant braking distance			0-255		50
53	Slow approach with ABC			0-255		48
54	Stopping time in push-pull operation, 1 to 256 sec			0-255		4
55	Sets brightness at function outputs A and C, 255=max			0-255		255

56	Sets brightness at function outputs B and D, 255=max	0-255	255
57	Function mapping: - Each bit of the CV stands for a function of the digital system: Bit 0(1) for function 1, Bit 1(2) for function 2 and so on up to Bit 7(8) for function 8. If you wish to allocate a function for dimming, the respective bit in CV 57 must be set.		
57	Dimming function (no factory setting)	0-255	0
58	Switching speed function (factory setting F3)	0-255	4
59	acceleration and deceleration delay function (factory setting F4)	0-255	8
60	Lighting effect at function outputs A and B. The units digit of the value stands for function output A, the tens digit for function output B: 0 No effect 1 Marslight 2 Gyrolight 3 Strobe 4 Double strobe	0-255	0
61	Function mapping: lighting effect at function outputs A and B	0-255	0
62	Lighting effect at function outputs C and D. The tens digit of the value stands for function output D: 0 No effect 1 Flashing at same time as function output C 2 Flashing alternately to function output C 3 Flickering type 2 (less smooth) 4 Flickering type 3 (excitedly) 5 Dimming with value from CV56	The units digit of the value stands for function output C: 0 No effect 1 Flashing 2 Flickering type 1 (smooth) 3 Dimming with value from CV55	0-255 0
63	Flashing frequency for function outputs C and D: default approx. 1 sec, $f = 1 / (0.03 * (1 + CV63))$		32
64	Function mapping: lighting effect at function outputs C and D		0
67.. 94	Values for user defined speed table, default = factory speed curve	0-255	
105	User Identification #1	0-255	255
106	User Identification #2	0-255	255
112	Duration of motor timeout when track signal has stopped. $t = CV112 * 0.016sec$, default approx. 0.25 sec	0-255	16
113	Minimum PWM value, control for motor types 4 or 5	0-255	40
114	Change duty cycle for motor type 4 or 5	0-255	10
115	Asymmetric DCC sensitivity	6-30	12
126	CV (<i>indicator</i>) for S.U.S.I., offset 800	0-255	102
127	CV (<i>transport device</i>) for S.U.S.I.	0-255	0
128	Decoder Software Version – read only		3

North American Warranty

Lenz GmbH does everything it can do to ensure that its products are free from defects and will operate for the life of your model railroad equipment. From time to time even the best engineered products fail either due to a faulty part or from accidental mistakes in installation. To protect your investment in Digital plus products, Lenz GmbH offers a very aggressive 10 year Limited Warranty.

This warranty is not valid if the user has altered, intentionally misused the Digital Plus product, or removed the product's protection, for example the heat shrink from decoders and other devices. In this case a service charge will be applied for all repairs or replacements. Should the user desire to alter a Digital Plus Product, they should contact Lenz GmbH for prior authorization.

Year One: A full repair or replacement will be provided to the original purchaser for any item that that has failed due to manufacturer defects or failures caused by accidental user installation problems. Should the item no longer be produced and the item is not repairable, a similar item will be substituted at the manufacturer's discretion. The user must pay for shipping to an authorized Lenz GmbH warranty center.

Year 2 and 3: A full replacement for any item will be provided that has failed due to manufacturer defects. If the failure was caused by accidental user installation or use, a minimal service charge may be imposed. Should the item no longer be produced and the item is not repairable, a similar item will be substituted at the manufacturer's discretion. The user must pay shipping to and from the authorized Lenz GmbH warranty center during this portion of the warranty period.

Year 4-10: A minimal service charge will be placed on each item that has failed due to manufacturer defects and/or accidental user installation problems. Should the item no longer be produced and the item is not repairable, a similar item will be substituted at the manufacturer's discretion. The user must pay shipping to and from the authorized Lenz GmbH warranty center during this portion of the warranty period.

Please contact your dealer or authorized Lenz GmbH warranty center for specific instructions and current service charges prior to returning any equipment for repair.

Hüttenbergstraße 29
35398 Gießen, Germany
Hotline: 06403 900 133
Fax: 06403 900155
info@digital-plus.de

Lenz
ELEKTRONIK GMBH
<http://www.lenz.com>

Lenz Agency of North America
PO Box 143
Chelmsford, MA 01824
ph: 978 250 1494
fax: 978 455 LENZ
support@lenz.com

This equipment complies with Part 15 of FCC Rules. Operation is subject to the following two conditions: (1) this device may not cause harmful interference, and (2) this device must accept any interference received, including interference that may cause undesired operation.

CE Please save this manual for future reference!

© 2005 Lenz GmbH, All Rights Reserved