

Four function universal decoder that is at home on all NMRA DCC systems. The characteristics of the decoder are:

Quality tested to follow all NMRA DCC Standards and RPs to achieve full compatibility with all compatible NMRA DCC systems.

- \* Designed for all locomotives with a continuous motor current: draw of up to 1.0 Amp
- \* Selectable for operation with 14/27, 28/55, 128 direct drive or 128 speed table mode with precision glide motor control.
- \* Four on/off function outputs 3 with a current rating of 100 mA and 1 with 500mA
- \* Headlights can be configured for directional lighting, full Rule 17 lighting, or lights and F1. Headlights can also be dimmed using an extra function.
- \* 2 extra functions can be set to blink or configured as ditch lights.
- \* Support for Advanced Consist Control and Extended Addressing
- \* Operation on conventional DC layouts is possible. This feature may be disabled.
- \* Full Support for operations mode programming (long and short) and full support for all forms of programming as described in NMRA RP-9.2.3
- \* Rich set of properties which the user can set to customize the decoder to a particular locomotive.
- \* Size : L 0.87" x W 0.63"x H 0.25" L 22.6mm x W 16mm x H 6.3mm

# LE113XF-JST Universal DCC Decoder

Art. No. 10123  
Version 4.5  
Revised 03/01

*Digital*  

---

*plus*  
*by Lenz* <sup>TM</sup>



Submitted to the NMRA  
C&I Committee for  
Testing

## ***The features of the LE113XF-JST Decoder***

The LE113XF decoder is packed with features you expect in a high end decoder. Independent or directional lighting (that can be dimmed using a function), full ditch light operation or 2 extra functions, advanced consist control, extended addressing, operations mode programming and full support for all the various speed step modes including 128 step motor control, are but a few examples of the advanced features found in the LE113XF. The LE113XF-JST supports all forms of programming described in NMRA Recommended Practice 9.2.3, including the user friendly direct CV programming mode. The advantages of this standardization are obvious: Every locomotive decoder responds in the same way no matter which DCC system you use. All new DIGITAL plus locomotive decoders are produced to fully conform to these NMRA DCC standards.

DIGITAL plus decoders built to the NMRA standards and recommended practices are labeled:



This prestigious label means that the NMRA has tested this product and found that it fully complies with all NMRA DCC Standards, Recommended Practices and industry norms. The LE113XF decoder has been submitted to the NMRA for testing.

Many characteristics of the LE113XF decoder can be programmed to customize the decoder to its locomotive. For example, you can operate the decoder with the factory pre-set speed table or generate your own. You can set which end of the locomotive is the forward end. You can even decide whether or not you want to be able to operate on conventional DC layouts.

Please read "Programming the LE113XF locomotive decoder" found later in this booklet for details on the configuration variables supported by the LE113XF. There you will find much more information regarding the features and their respective settings.

---

## Preparing to Install the LE113XF-JST

The locomotive should be operating well on normal DC power before installing the decoder. Replace worn out motor brushes and burned out light bulbs. Clean any dirt or oxidation from the wheels and pickups, and make sure that electrical contact is smooth. Now is also a good time to lubricate your locomotive. A locomotive that runs well under DC will run exceptionally well under DCC.

### ***Some advice on the current draw of the decoder:***

The current for all the decoder outputs is supplied by an internal rectifier with a maximum current rating of 1.2 Amps. The sum of all currents to the motor and the function outputs cannot exceed this limit. Each individual output can only draw up to its limit.

#### **Example:**

Suppose the motor may require as much as 1.0 A continuously. Then the function outputs combined must not exceed 0.2 A. If the directional headlights require 50 mA each, then the load on function 1 must not exceed 100 mA.

### ***Some advice on installing the decoder:***

Although the LE113XF has many internal safeguards to prevent damage, you must not allow any metal part of the locomotive to touch the surface components of the decoder. This could cause a direct internal short circuit and the decoder will be destroyed. **The motor brushes MUST also be completely isolated from the rail pickup.** Achieving isolation may require some different approaches on different locomotives, perhaps unsoldering wires, placing a thin piece of insulating plastic between brush terminal and contact spring. If you have a VOM, check for infinite resistance between the motor and all the wheels. Take special note that metal contact might occur only when the loco body is reinstalled.

### ***DO NOT WRAP decoder with electrical tape or shrink wrap!***

Doing so will impede air circulation and degrade the performance of the decoder. Instead, put electrician tape over any part of the locomotive frame or body that might touch the decoder and use double sided foam mounting tape to mount the decoder. This will prevent short circuits without 'suffocating' the decoder.

The LE113XF can not be set up for simultaneous use for 2-rail pickup and overhead cantenary or trolley operation. If the locomotive is turned the wrong way, the decoder could get twice the track voltage, which would destroy it!

## Wiring Options

There are two wiring options for installing the LE113XF, depending on how the locomotive is constructed. The three functions could be connected with their common to the track voltage as shown in Figure 1, or use the decoder's floating common as shown in Figure 2. A mixture of both options is also possible. If the bulbs for the

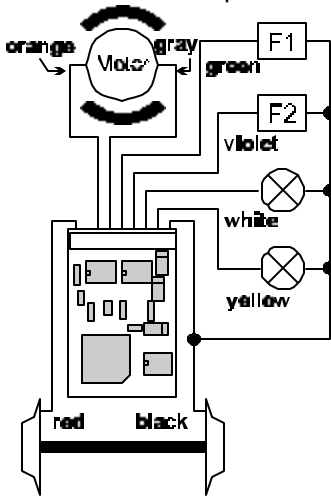

Figure 1: Wiring the LE113XF using track voltage common

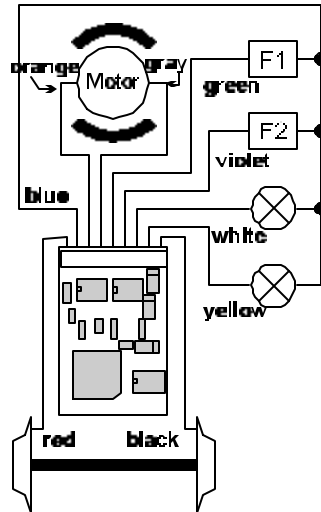

Figure 2: Wiring the LE113XF using a floating common.

headlights are floating (isolated against wheel pick up and chassis) and connected according to Figure 2, they will shine brighter compared to the option shown to Figure 1. Furthermore, the directional headlights will function while operating on conventional DC layouts.

## Step by Step Installation

If the locomotive has a NMRA JST decoder socket simply remove the dummy plug and plug in the decoder. The following instructions apply if you need to install one of the various available JST harnesses.

Two wires connect the decoder to the motor. Make sure that the motor is electrically isolated from both track pickups:

- Orange wire to the motor terminal that was previously connected to the right rail (Pin #1).
- Gray wire to the motor terminal that was previously connected to the left rail (Pin #5).

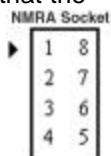

Two wires connect the decoder to the track electrical pickups:

- Red wire to right rail pickup (Pin #8).
- Black wire to the left rail pickup (Pin #4).

Five wires connect the headlights and functions to the decoder:

- White wire (Pin #6) to the forward headlight or the function controlled by Output A. If the bulb is isolated, connect the blue wire (Pin #7) to the other terminal.
- Yellow wire (Pin #2) to the rear headlight or the function controlled by Output B. If the bulb or function is isolated, then connect the blue wire (Pin #7) to the other terminal.
- Green wire (Pin #3) to function controlled by Output C. If the bulb is isolated, connect the blue wire (Pin #7) to the other terminal.
- Violet wire to function controlled by Output D. If the bulb is isolated, connect the blue wire (Pin #7) to the other terminal.

Place the locomotive (without its shell) on the programming track and read back the locomotive's address from the decoder. If the decoder is properly installed, you will be able to read back the factory pre-set address 03. Remove the locomotive from the track, and if necessary correct any wiring errors.

## Special lighting examples

Following are but a few examples of popular special effects. Please refer to the complete CV definitions for complete explanations of CV values.

### Example 1: Non directional dimmable front headlight, independent rear light and ditch lights.

Connect the white wire to the front headlight, the yellow wire to the rear headlight the green wire to one ditch light and the violet wire to the other ditch light. F0 turns on front light; F4 dims the front

headlight if F0 is on; F1 turns on the rear light; F3 turns on the ditch lights; and F2 alternates the two ditch lights if F3 is on.

CV51 = 07, CV52 = 128 (higher value brighter when dimmed) CV53 = 04, CV54 = 04, CV55 = 04, CV56 = 15 (higher value slower blinking rate)

### **Example 2: Directional bright headlight, other headlight dimmed, one beacon, and one cab light**

Connect the white wire to the front headlight, the yellow wire to the rear headlight, connect a 490 ohm resistor between the front and rear headlights, the green wire to the beacon and the violet wire connects to the cab light. F0 turns on light in the direction of travel bright and the other light dim; F1 turns on the beacon; and F3 turns on the cab light.

CV51 = 00, CV53 = 01, CV54 = 01, CV55 = 04, CV56 = 15

### **Example 3: Mars light and two functions**

Connect the white wire and green wires to the front headlight, the yellow wire and violet wire connect to two other functions of your choice. F0 turns on front light; F4 converts the front headlight to a mars headlight if F0 is on; and F1 and F8 can be used for two other functions of your choice.

CV51= 07, CV52= 75, CV53= 01, CV54= 10, CV55= 128, CV56= 23

## ***Programming the LE113XF locomotive decoder***

Any NMRA DCC programmer can be used to configure the locomotive decoder LE113XF-JST. With several entry level systems only a few CVs (such as CV #1, the locomotive address) can be set unless you use a separate programmer. The LE113XF-JST supports all modes and can be programmed by all NMRA DCC programmers. Specific details for reading and writing the decoder's configuration variables can be found in the manuals of the appropriate equipment.

### ***The configuration variables and their meaning***

The following table lists the various CVs supported in the LE113XF-JST decoder. Both the New CV numbers and the older Register numbers are provided for cross reference.

*Please note: Some CVs (such as CV29) have specific meanings for each bit. The bit assignments in this table use a bit numbering*

scheme of 0-7 to correspond the NMRA convention for universal bit numbering. Many handhelds (such as the DIGITAL plus LH100 handheld) use a scheme of 1-8 to refer to the individual bits rather than 0-7. (Bit 0 in this table is displayed as a "1" on LH100 handheld, Bit 1 is identified as "2".) The bit numbers in () within these tables contain the LH100 bit numbers.

**Table 1: LE113XF-JST Configuration Variables**

CV	Reg	Description	Range	Factory setting
1	1	<b>Locomotive address:</b> This is the number with which you select a locomotive in the DIGITAL plus system. Setting the address from #1 to #3 using register mode will reset the decoder to utilize 14 speed step operation.	1-127	3
2	2	<b>Start voltage:</b> This is the voltage applied to the motor in speed step 1. Set this value so that the locomotive just starts moving in speed step 1.	0-31	8
3	3	<b>Acceleration Momentum:</b> Determines the rate of change of speed upon acceleration. A higher value leads to a slower acceleration.	1-31	1
4	4	<b>Brake Momentum:</b> Determines the rate of change of speed upon braking. A higher value leads to longer brake distance.	1-31	1
-	5	<b>Contains CV29 (see CV29 below)</b>	0-55	6
-	6	<b>Page Register:</b> Normally this CV is not modified directly by a user. For correct operation, this CV should be set to have a value of 1 after any use.	0-127	1
7	7	<b>Version Number:</b> This location contains the version number of the decoder. This location is read only.	-	45
8	8	<b>Manufacturers Identification / Factory reset</b> Contains the manufacturer ID of the decoder, (Lenz =99). Writing a value of 33 using Register mode resets all CVs to their factory condition	-	99
17	-	<b>Extended Address High Byte</b>	192-231	0
18	-	<b>Extended Address Low Byte</b> The two byte address if used is contained in CV17+18	0-255	0

\*\*Note: in the factory setting field the numbers in the [ ] are decimal.

CV	Description	Range	Setting
19	<b>Consist Address</b> The advanced consist address if used is stored in CV19	0-255	0
23	<b>Acceleration Trim</b> This Configuration Variable contains additional acceleration rate information that is to be added to or subtracted from the base value contained in CV3	0-255	255
24	<b>Deceleration Trim</b> This Configuration Variable contains additional braking rate information that is to be added to or subtracted from the base value contained in CV4	0-255	255
29	<b>Decoder Configuration, Byte 1:</b> Several decoder properties are set with this byte. Changes are easiest if done in binary mode, but can also be done by adding the decimal ( ) for all the features desired together and writing the total into CV29. The detailed properties are:	0-55	6
	bit 0 (1) <b>locomotive direction:</b> Locomotive's relative direction: This bit sets the direction the locomotive will move when told to move forward in digital mode. 0 = locomotive's direction is normal 1 = locomotive's direction is inverted	0,1	0  [1]
	bit 1 (2) <b>Headlight mode:</b> 0 = Operation with 14 or 27 speed step systems. This setting is selected when the locomotive decoder is used with any Digital system that does not support 28 speed step mode. If the headlights turn on and off as the speed is increased, the command station is configured for 28 speed step mode, and the decoder is in 14 speed step mode. 1 = Operation with 28, 55 or 128 speed steps. If you use this setting, the Command Station must also be configured to use 28 speed step mode or 128 speed step mode for the decoder's address, otherwise the headlights can not be controlled.	0,1	1  [2]
	bit 2 (3) <b>Usage on conventional DC layouts:</b> 0 = locomotive operates in digital mode only 1 = locomotive can operate on either conventional DC and on DCC	0,1	1  [4]
	bit 3 always 0	0	0
	bit 4 (5) <b>Speed Curve Selection:</b> 0 = factory pre-set speed curve is used 1 = user defined speed curve is used. Please enter the appropriate values into CV 67 to 94 before setting this bit.	0,1	0  [16]



CV	Description	Range	Setting
	bit 5 (6) <b>Extended Addressing:</b> 0= Normal addressing 1=Two Byte extended addressing	0-1	0  [32]
	bits 6-7	0	0
<b>50</b>	<b>Decoder Configuration, byte 2:</b> Similar to CV 29, but used to set other properties		0
	bit 0		not used
	bit 1 (2) 0 = CV23 and CV24 are not active 1 = CV23/CV24 are active and contain the acceleration and deceleration trim values that are added to CV3 or CV4.	0,1	0 [2]
	bit 2 (3) <b>Brake momentum on DC operation.</b> Used to achieve prototypical braking at red signal indications if conventional DC control CV29.2 is disabled. (CV 29 bit 2 = 0) 0 = locomotive proceeds with track voltage dependent speed inside the conventional DC section. 1 = locomotive brakes in the conventional DC section with pre set brake momentum.	0,1	0 [4]
	bits 3-7		not used
<b>51</b>	<b>Lighting Special Effects for Outputs A and B</b>		0
	bit 0 (1) 0 = the headlights are directional. 1 = the lights are independent per Rule 17. F0 controls the front headlight and F1 the rear headlight or a separate function.	0,1	0 [1]
	bit 1 (2) 0 = function dimming disabled 1 = the value in CV52 is used for headlight/function dimming.	0,1	0 [2]
	bit 2 (3) 1= if CV51.0 and CV51.1 both =1 (dimming and Rule17 are both active), F4 dims F0. If CV51.0 = 0 and CV51.1 =1 (directional dimming) then F1 dims the forward headlight if on.	0,1	0 [4]
	bit 3 (4) 1= if CV51.0 and CV51.1 both =1 (dimming and Rule 17 are both active), F4 dims F1. If CV51.0 = 0 and CV51.1 =1 (directional dimming) then F1 dims the rear headlight if on.	0,1	0 [8]
	bits 4-7		Not used
<b>52</b>	<b>Dimming CV</b> - contains the value used for dimming. 0 is dark 255 is max brightness	0-255	64

CV	Description	Range	Setting
<b>53</b>	<b>Lighting Special Effects for Outputs C and D</b>		0
	bit 0 (1) 1 = Output C blinks with the frequency set in CV56	0,1	0 [1]
	bit 1 (2) 1 = Output D blinks with the frequency set in CV56	0,1	0 [2]
	bit 2 (3) 1= Outputs C and D act as Ditch Lights. F2 controls alternate blinking when Output C is on. CV 54 and CV55 should be set to have identical values.	0,1	0 [4]
<b>54</b>	<b>Function assignment for Output C</b>		1
	bit 0 (1) 1 = Output C is controlled By F1	0,1	1 [1]
	bit 1 (2) 1 = Output C is controlled By F2	0,1	0 [2]
	bit 2 (3) 1 = Output C is controlled By F3	0,1	0 [4]
	bit 3 (4) 1 = Output C is controlled By F4	0,1	0 [8]
	bit 4 (5) 1 = Output C is controlled By F5	0,1	0 [16]
	bit 5 (6) 1 = Output C is controlled By F6	0,1	0 [32]
	bit 6 (7) 1 = Output C is controlled By F7	0,1	0 [64]
	bit 7 (8) 1 = Output C is controlled By F8	0,1	0 [128]
<b>55</b>	<b>Function assignment for Output D</b>		2
	bit 0 (1) 1 = Output D is controlled By F1	0,1	1 [1]
	bit 1 (2) 1 = Output D is controlled By F2	0,1	0 [2]
	bit 2 (3) 1 = Output D is controlled By F3	0,1	0 [4]
	bit 3 (4) 1 = Output D is controlled By F4	0,1	0 [8]
	bit 4 (5) 1 = Output D is controlled By F5	0,1	0 [16]
	bit 5 (6) 1 = Output D is controlled By F6	0,1	0 [32]
	bit 6 (7) 1 = Output D is controlled By F7	0,1	0 [64]
	bit 7 (8) 1 = Output D is controlled By F8	0,1	0 [128]
<b>56</b>	<b>Blinking Rate for Outputs C and D.</b> Frequency in Hz = $1/0.016*(1+CV56)$	0-255	30
<b>67 to 94</b>	<b>Values for user defined speed curve:</b> These registers are used for a user defined speed curve. The factory setting for these registers is shown in the following speed curve table. The value in each CV determines the velocity of the locomotive for each assigned speed step: For the 14 speed step mode the odd CVs are used If you are using 128 speed step mode and you have activated the user defined speed table, the intermediate speed steps are calculated by the decoder.	0-255	Factory Default Speed Curve
<b>105</b>	<b>User Identification #1</b>	0-255	255
<b>106</b>	<b>User Identification #2</b>	0-255	255
<b>128</b>	<b>Decoder Software Version – read only</b>		04

## Creating a Speed Curve

One common feature is to set a specific operating speed curve for your locomotives. This is usually done to have dissimilar locomotives have the same performance characteristics or to have the locomotives perform more prototypically. Start by writing down how you want to assign the internal speed settings to the speed steps, for example by making up a table as shown below.

Note: CV2 (Start Voltage) is still used as part of the calculation even when the decoder is in User Defined Speed Curve mode.

Speed step in 14/27 mode	Speed step in 28 mode	Default speed setting	CV / register
1	1	4	67
	2	8	68
2	3	12	69
	4	16	70
3	5	20	71
	6	24	72
4	7	28	73
	8	33	74
5	9	38	75
	10	43	76
6	11	48	77
	12	53	78
7	13	60	79
	14	67	80
8	15	74	81
	16	82	82
9	17	90	83
	18	98	84
10	19	106	85
	20	115	86
11	21	125	87
	22	137	88
12	23	152	89
	24	178	90
13	25	194	91
	26	212	92
14	27	232	93
-	28	255	94

In 128 speed step mode the decoder internally averages the speed table to obtain the correct speed step value.

## North American Warranty

Lenz GmbH does everything it can do to ensure that its products are free from defects and will operate for the life of your model railroad equipment. From time to time even the best engineered products fail either due to a faulty part or from accidental mistakes in installation. To protect your investment in Digital Plus products, Lenz GmbH offers a very aggressive 10 year Limited Warranty.

This warranty is not valid if the user has altered, intentionally misused the Digital Plus product, or removed the product's protection, for example the heat shrink from decoders and other devices. In this case a service charge will be applied for all repairs or replacements. Should the user desire to alter a Digital Plus Product, they should contact Lenz GmbH for prior authorization.

**Year One:** A full repair or replacement will be provided to the original purchaser for any item that has failed due to manufacturer defects or failures caused by accidental user installation problems. Should the item no longer be produced and the item is not repairable, a similar item will be substituted at the manufacturers discretion. The user must pay for shipping to an authorized Lenz GmbH warranty center.

**Year 2 and 3:** A full replacement for any item will be provided that has failed due to manufacturer defects. If the failure was caused by accidental user installation or use, a minimal service charge may be imposed. Should the item no longer be produced and the item is not repairable, a similar item will be substituted at the manufacturers discretion. The user must pay shipping to and from the authorized Lenz GmbH warranty center during this portion of the warranty period.

**Year 4-10:** A minimal service charge will be placed on each item that has failed due to manufacturer defects and/or accidental user installation problems. Should the item no longer be produced and the item is not repairable, a similar item will be substituted at the manufacturers discretion. The user must pay shipping to and from the authorized Lenz GmbH warranty center during this portion of the warranty period.

Please contact your dealer or authorized Lenz GmbH warranty center for specific instructions and current service charges prior to returning any equipment for repair.

Hüttenbergstraße 29  
35398 Gießen, Germany  
Hotline: 06403 900 133  
Fax: 06403 900155  
info@digital-plus.de



Lenz Agency of North America  
PO Box 143  
Chelmsford, MA 01824  
ph: 978 250 1494  
fax: 978 455 LENZ  
support@lenz.com

This equipment complies with Part 15 of FCC Rules. Operation is subject to the following two conditions: (1) this device may not cause harmful interference, and (2) this device must accept any interference received, including interference that may cause undesired operation.



Please save this manual for future reference!