

General characteristics

- * The LV200 was developed especially for the increased electric power requirements of model railways the larger scales (S, O, Large Scale).
- * The LV200 is not suitable for operation with HO or smaller scales.
- * For best operations use Crest CRE-55465 Switching Power Supply
- * measurements : 120 x 55 x 120 mm

LV200 10 Amp Power Station

Art. No. 22200
Revised 2/02

Digital
— *plus*
by *Lenz*™

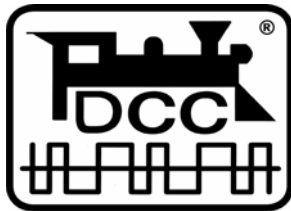

Submitted to the NMRA for testing

Important safety instructions

Do not leave your model railway system in operation when it is not being supervised! If a short-circuit goes unnoticed, the heat produced causes a risk of fire!

The LV200 is authorised for operation only with a UL or CE approved transformer such as the *Digital plus by Lenz*®, TR200, the Crest CRE-55465 10 amp transformer, or the LGB - "Jumbo".

The heat produced by the power station in operation is normal. You must provide sufficient air circulation around the power station in order to prevent the internal protective system from reacting prematurely, that is, during normal operation.

No radio interference suppression capacitor may be installed in the track system. This capacitor is necessary only for the interference suppression in conventional operation. If used with the *Digital plus by Lenz*® system, however, it would distort the data format and interfere with the fault-free transmission of data.

A mixed digital operation using overhead lines and track is not permitted. In such a mode of operation, if the locomotive is sitting on the track in the wrong direction (which might be the case e.g. after having driven through a terminal-loop), the installed locomotive decoder can be destroyed by overvoltage! We recommend operation using track pick-up, because the reliability of contact (and therefore the transmission of digital signals to the locomotive decoder) is substantially greater than it is when operating with overhead lines.

What is the purpose of the power station LV200?

Together with a suitable model railroad transformer, the LV200 serves to supply current to your model railway.

The power station LV200 can be compared to the amplifier (output transformer) of stereo equipment: the audio signal produced by the CD player has to be amplified, otherwise you could not hear anything coming from the loudspeakers.

The track-signal produced by the LZ100 or LH200 command stations contains the information used by the locomotive

decoder and the switch decoder. From this information the decoders learn whether the motor of the locomotive is to rotate fast or slowly, whether the lights are to be switched on or off, and whether the turnout points should be set on "straight ahead" or "branch off". This track signal alone, however, is not enough to enable operation. It must first be amplified in such a way that, in addition to the information, the required current- supply can also flow. This amplification is the task of the LV200.

Connecting the LV200 to your DCC System

On the back of LV200 you will find the following connections:

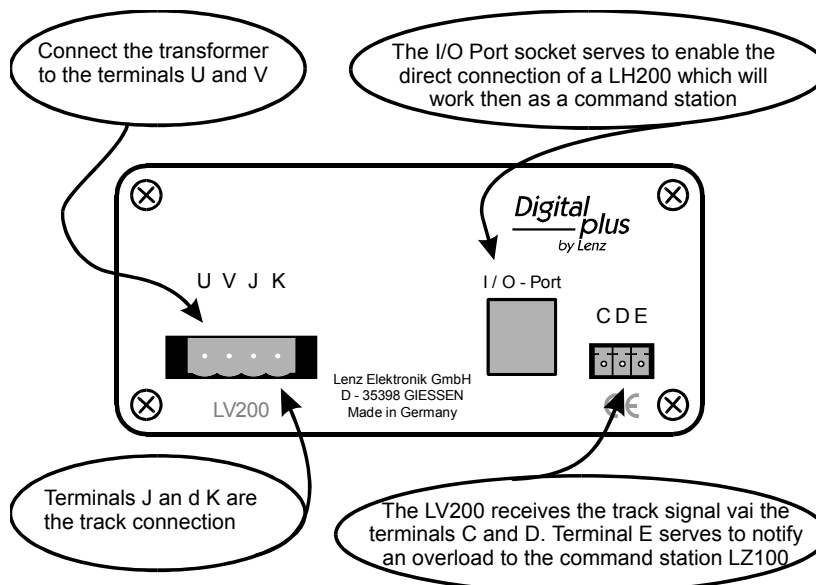

The terminals U and V as well as J and K are designed for a maximum cable cross-section of 12 AGW wire. For the currents made available by LV200 you should use a minimum cross-section of 16AGW.

The terminals C and D are to be connected to the terminals C and D of the LZ100 command station via a two-wire cable. For reasons of interference immunity the cable should be twisted.

The cross-section of the cables of the terminals C, D and E should not be smaller than 26 AGW, for distances of 4m and longer we recommend 24 AGW. The maximum cross-section for these terminals is 16 AGW.

When you optionally connect terminal E of the LV200 with terminal E of the LZ100 command station, the command station is informed of the overloading of the power station. The command station will then transfer this information to all input equipment (manual control etc.) and turn off the DCC track signal to all other power stations. The display of the LZ100 will then inform you regarding the switching-off of power or resuming operation.

If you do not connect terminal E of the LV200 with the LZ100 command station, then when an overload occurs, the LV200 only shuts down the track area it is connected and the LZ100 will not shut down any other power station on the layout. After a certain time (when the LV200 power station has cooled down) the LV200 power station will switch on the current supply TO ITS TRACK SECTION automatically. If the overloading still exists, THE LV200 will switch off again after a short period of time.

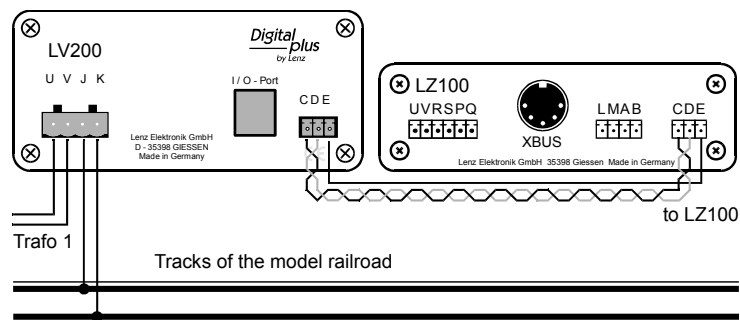

Connecting the LV200 to the command station LZ100

Selecting the Right Transformer for the LV200

It is important that to select a suitable transformer for powering the LV200. The best transformer for the LV200 is the Crest CRE-55465. This switching power supply will provide you the correct DCC track voltage and will not sag under load. Voltage that exceed the maximum voltages could potentially damage

Decoders. If you use a transformer that delivers less than 10 amps, you will not be able to operate as many trains.

Operating voltage (input voltage)

The LV200 is designed for the following input voltages:

Crest CRE-55465	22VDC or 13.8 V DC
TR200 (220VAC):	26V peak-voltage corresponds to 18V AC effective output
LGB – Jumbo:	16-24V DC
Generic Transformer:	O and S scales 13V AC or 14 DC Large Scale 16V AC or 22V DC

Note: The LV200 will shut down if the input voltage after rectification exceeds 24 volts.

Voltage on the track (output voltage)

In general, the DCC track voltage is a little less than the input voltage. When the supply is

Crest CRE-55465	13.3 volts DCC or 21.4 volts DCC depending on power supply setting
AC (TR200):	connected to 18V terminal: 25.5V without load, 20.0V at 8A. connected to 15V terminal: 21.2V without load, 16.5V at 8A
DC (LGB - Jumbo)	the output voltage is approx. 1.5V less than the input voltage.

Output current available to the railroad

The maximum output current of LV200 depends on the kind of input voltage and the performance of the supplying transformer.

The following are the respective maximum output currents:

Crest CRE-55465	10 Amps (continuous)
AC (TR200):	8 Amps
DC (LGB-Jumbo):	10 Amps
Generic 12 Amp Transformer:	10 Amps or less

The luminous diode

The luminous diode at the front of the LV200 provides information on the operating situation:

green, constant:	Everything is ok, there is operating voltage and the DCC signal is being sent to the track.
green, flashing:	The LV200 is not receiving a digital signal via the terminals C, D. There is operating voltage, and the voltage on the tracks is switched off. Causes: <ul style="list-style-type: none"> - The system was brought to Emergency STOP (e.g. by switching it off at the manual control) - The cable connection C,D between LV200 and the command station has been interrupted - When using an LH200 as a command station, the plug has been pulled out of the I/O-Port socket. - The system is in programming mode (in such cases the command station LZ100 switches off the track signal).
red:	Fault due to: <ul style="list-style-type: none"> - Overload, overheating (the maximum starting voltage has been exceeded) - Overvoltage (the permitted maximum input voltage has been exceeded)

Six-Pin I/O - Port

The new six-pin phone type jack located on the rear of the LV101 is provided for use with the LH200 when used as a command station. The wire connections for this I/O port are shown in below.

CAUTION:

Do not plug in another manufacturers 6 pin wire into this jack as each manufacturer defines the use of these wires differently. Plugging in a different manufacturers equipment into the IO port could destroy one or both pieces of equipment and this is not covered by our warranty.

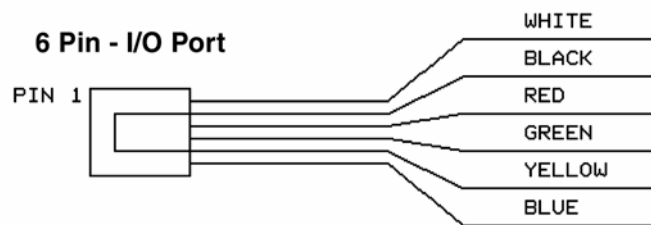

Wire connections for the LV200 6 pin -I/O port

Pin #	Color	Description
Pin 1	White	"C" Control Bus Connection
Pin 2	Black	Ground
Pin 3	Red	- RS-485
Pin 4	Green	+ RS-485
Pin 5	Yellow	+12 volts
Pin 6	Blue	"D" Control Bus Connection

Connecting the LV200 to Other DCC Systems

The LV200 has been designed to be used with a broad range of NMRAs DCC systems. Following are diagrams to assist you in connecting the LV200 to other systems.

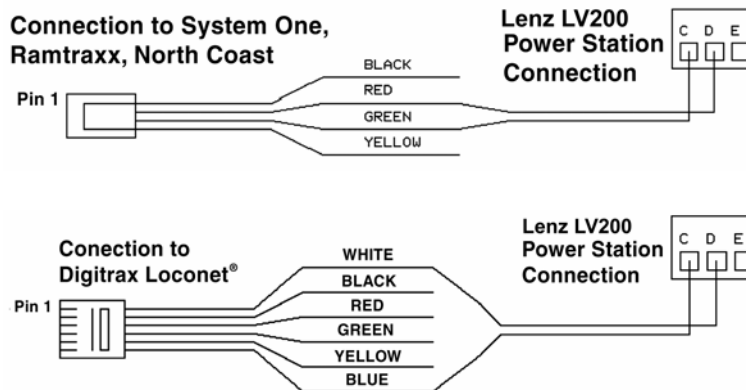

Determining the power requirements of your model railway

As with conventionally operated systems and layouts, a sufficient supply of electricity to the system is a precondition for the sure and safe functioning of the Digital plus by Lenz® systems. Locomotives, coach lights, points, signals etc. receive their power and control information from the power station.

The power consumption of your model railway system consists of:

Running locomotives	Depending on size and attached load, the power consumption varies extremely. A small, single LGB-locomotive with one motor can make do with approx. 1.5A of current; a large one with two motors (e.g. Crocodile) reaches peak currents of 4-5A. The maximum current consumption of the motors of locomotives is decisive in the selection of the right decoders! Therefore it is necessary that you measure the current-consumption or that you ask the producer of the locomotive for information.
Standing locomotives	approx. 2.5 mA, this is the idle current consumption of the decoder.
illuminated locomotives	each bulb approx. 50 mA.
illuminated coaches	each bulb approx. 50 mA.

In the area supplied by a LV200, the current consumption of all locomotives running in this area at the same time (plus the current consumption of the lights of the coaches) must not exceed the maximum current that can be delivered by the LV200.

If the total current consumption of all the locomotives, coaches, signals etc connected to the LV200 exceeds the current that can be delivered by the LV200, the protective system will be activated: the voltage on the tracks will be switched off and the LED will shine red.

If the performance of one LV200 is not sufficient for the system then divide the layout into several supply areas. Further LV200s can then be used to supply these areas with current.

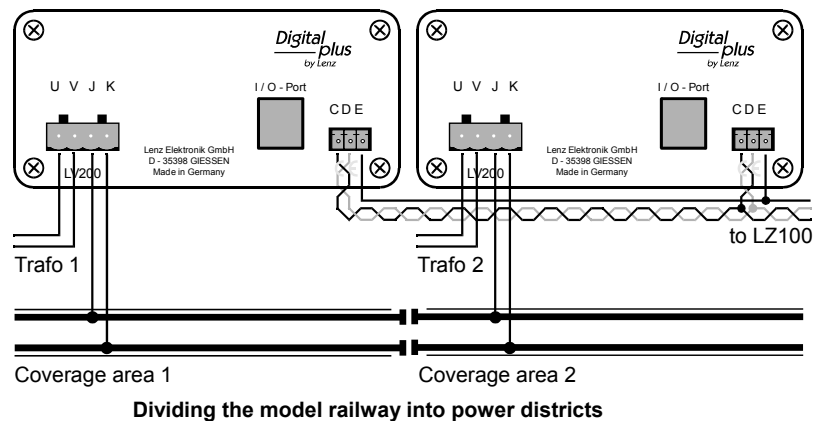

The additional LV200s receive the control signals from the terminals C and D of the first LV200. Each LV200 has to be connected to its own transformer. The number of power station-transformer-units needed depends on the overall power consumption of your model railway.

It is absolutely necessary that the electric circuits of all the LV200's are the same polarity. Thus, terminal J of one and terminal J of the next LV200 must be connected to same side of the track in question. Otherwise short-circuits will occur when operating a locomotive over gaps that divide the power districts.

Advice on the wiring of the model railway

Use only cables with a minimum cross section of 16 AGW when connecting the tracks and twist these cables. Moreover, the power station should always be placed as close as possible to the first point of power supply.

For extended routes you need additional track power connections at regular intervals. Rule of thumb: every 3m.

No capacitor for interference suppression may be installed into the track system. Such a capacitor is necessary for the interference suppression only in conventional operation. When used with the Digital plus by Lenz® system it would, however, distort the data format and interfere with the fault-free transmission of data.

Common Rail Wiring

Normally both rails are gapped between power stations. This provides complete isolation. However, in some scales there exist locomotives that have pickups that are offset from each other. For example many steam locomotives have power pickup from one rail in the locomotive and the other rail in the tender. When such a locomotive bridges the gap between isolated power stations, the locomotive will stall. The solution to this problem is to provide a common wire between all power stations. All systems of command control need to have a such a common provided, if offset pickup locomotives are to be operated.

Lenz has chosen to leave the option of the location of the common up to the individual operator. The LV200 is completely opto-isolated. This allows you to use one of the rails (called common rail) for your common. Common rail wiring is also compatible with many existing signaling systems. While common rail is the preferred place for a common, you may instead connect all the power station **U** or **V** wires together. This is called common power supply wiring.

Caution: If you decide to install a common, it is important that you only have a single common. Multiple commons (such as common rail and common transformer) should be avoided.

Connecting a reverse loop

Lenz GmbH produces an automatic reversing module (LK100) which can be used to easily wire complex automatic reversing sections. While these units are invaluable in some cases they are not absolutely needed for DCC operations. Following is an example on how a very simple reversing section can be built.

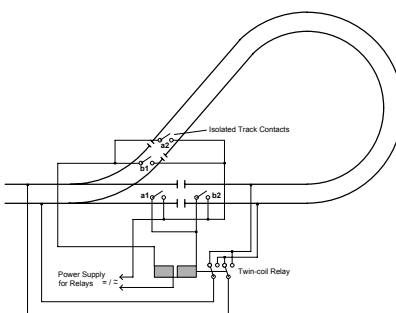

Wiring of Reverse Loops

Using isolated track contacts and a twin-coil relay, the polarity inside a reverse loop is switched such that when crossing the gaps, there is no short. For example; when the train travel is in clockwise direction (turnout is set to diverging route), the polarity of the loop is set to allow the train to cross the gap without a short. When the turnout is subsequently switched to straight operation the relay will switch the polarity in the loop, and the exit gap can be crossed safely. Since in digital operations the direction of travel is dependent on the locomotive and not track polarity, the locomotive will not change its direction of travel when the polarity within the reverse loop is changed.

Using Digital Operation with Overhead Wire

A mixed digital operation with overhead line and track is permitted only if overhead line and track line **originate from the same power station**.

On no account may the track be connected to one power station while the overhead line is connected to another. With such wiring, if the locomotive is set on the track in the wrong direction (e.g. after having driven through a terminal-loop), the installed locomotive decoder will be destroyed due to over voltage!

Help in case of malfunctions

Fault	Possible cause	Elimination of problem
LV200 is not ready for work (LED does not shine).	Electric power supply is interrupted. Transformer mains-plug not plugged in.	Check wiring between transformer and LV200, plug in transformer mains-plug.
LED flashes green, locomotives do not run, points and signals can not be switched.	The connection between LV200 and the command station LZ100 is interrupted or short-circuited (terminals C and D).	Check and correct the connections.
	The command station does not transmit a track signal, because the system was set on "Emergency Stop".	Switch the system on again. For more information on this, see the operation manual for the input equipment.
	When using the LH200 as command station the plug was unplugged from the I/O socket.	Put the plug back into the socket again.
	The system is set on the programming mode; therefore the command station has switched off the track signal.	Finish the programming mode. For more information please see the operation manuals for the input equipment.
LED shines constantly red, locomotives do not run, points and signals can not be switched.	There has been a short-circuit on the track system.	Deal with the short-circuit.
	There is overloading.	Divide the system into several coverage areas and supply them with additional s/ transformers
LV200 is ready to work (LED shines constantly green), locomotives do not run, and turnouts and signals can not be switched.	The connection of the power station and the track and / or the switch decoder is interrupted (terminals J and K not connected).	Check and correct the connections.

Not suitable for children under three because of the danger of their swallowing the small constituent pieces. Improper use can result in injury by functionally necessary points and edges. For use only in dry areas. We reserve the right to make changes in line with technical progress, product maintenance or changes in production methods. We accept no responsibility for errors, which may occur for similar reasons. We accept no responsibility for direct or indirect damage resulting from improper use, non observance of instructions, use of transformers or other electrical equipment which is not authorized for use with model railways or transformers or other electrical equipment which is not authorized for use with model railways or transformers or other electrical equipment which has been altered or adapted or which is faulty. Nor can we accept responsibility when damage results from unsupervised adjustments to equipment, from acts of violence, from overheating, or from the effects of moisture etc. Furthermore, in all such cases guarantees become invalid.

Hüttenbergstraße 29
35398 Gießen, Germany
Hotline: 06403 900 133
Fax: 06403 900155
info@digital-plus.de

Lenz
ELEKTRONIK GMBH

<http://www.lenz.com>

Lenz Agency of North
America
PO Box 143
Chelmsford, MA 01824
ph: 978 250 1494
fax: 978 455 LENZ
support@lenz.com



This equipment complies with Part 15 of FCC Rules. Operation is subject to the following two conditions: (1) this device may not cause harmful interference, and (2) this device must accept any interference received, including interference that may cause undesired operation.



Please save this manual for future reference!

© 2002 Lenz GmbH, All Rights Reserved